

**ORDERING INFORMATION:**

**PART NUMBER:** SP-1 - LT - NPS - T - A - L

**EXAMPLE:** SP-1 - LT - 6 - 1/2 - 60 - 12  
 [12.7mm] [304.8mm]

SP-1-LT SMARTPAD LITE  
 6 NOMINAL PIPE SIZE  
 [12.7mm] 1/2 THICKNESS  
 60 PIPE COVERAGE ANGLE  
 [304.8mm] 12 LENGTH

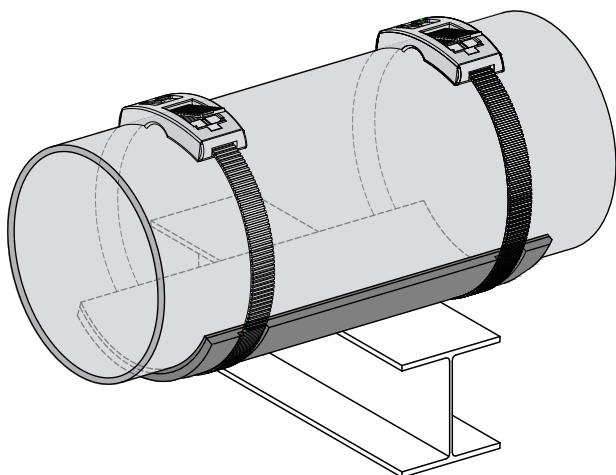

PIPE SIZE (NPS)	PAD THK. "T" (NOTE 3)	STANDARD ANGLE "A" (NOTE 3)	STANDARD LENGTH "L" (NOTE 3)
	IN. [mm]		IN. [mm]
3/4 - 4	1/2" [12.7mm]	90°	12" [304.8mm]
6 - 10	1/2" [12.7mm]	60°	12" [304.8mm]
12 - 16	1/2" [12.7mm]	45°	12" [304.8mm]
18 - 24	1/2" [12.7mm]	45°	18" [457.2mm]

OTHER SIZES AVAILABLE, CONTACT COGBILL FOR MORE INFORMATION

**NOTES:**

1. RedLineIPS SmartPad is made from vinyl ester resin material, as manufactured by Cogbill Construction.
2. SmartPad is secured to the pipe using the RedLineIPS composite banding system (SmartBand) as per the RedLineIPS installation procedure.
3. Various thicknesses, angles of coverage, and lengths are based on the specific design parameters of the piping system and are available upon request.
4. Operating temperature range is -60°F (-51°C) to 400°F (204°C).
5. RedLineIPS SmartPads include a pre-installed RedLineIPS Gasket for sealing it to the pipe, offering a NEMA 4 watertight seal to prevent corrosion.
6. 50,000 lbs (22,680 kg) compressive strength.

REV	DESCRIPTION	BY	CHK.	DATE	PIPING STANDARD DETAILS					
					<div style="text-align: center;"> <p>RedLineIPS NON-METALLIC SMARTPAD LT FOR PIPE</p>  <p>2325 S MAIN ST. VIDOR, TX 77662 409-768-1419 www.RedLineIPS.com Info@RedLineIPS.com</p> </div>					
0	ISSUED FOR CONSTRUCTION	GT	HA	11/20/2019						
A	ISSUED FOR APPROVAL	GT	HA	7/10/2019						
DRAWING NUMBER: SP-1- LT								DRAWN BY: GT 07/10/19	CHKD BY: HA 07/10/19	REV: 0
								APPD BY: WC 07/10/19	SCALE: NTS	SHEET: 1 OF 1